

Research on a highway truck anti-deflection load system

Yanshun Ma, Yi Shi, Yihang Song, Shuwei Tian, Yuwei Ma, Yongming He, Shuai Sun

College of Civil Engineering and Transportation, Northeast Forestry University, Harbin 150040, China

Abstract: In order to improve the safety of road trucks, an anti-bias load system for road trucks is proposed. The system integrates real-time monitoring and safety alarm functions, and is composed of sensor components and on-board control units. The system is installed on the truck axle, through the single-chip computer calculation and monitoring technology, real-time monitoring of the truck load, especially the detection of the off-load state. Once the off-load situation occurs, the device immediately issues a safety alarm to remind the driver to take necessary measures to reduce the risk of truck rollover and other accidents and improve road traffic safety. The research results are expected to enhance the stability and safety of trucks and promote road traffic technology innovation.

Key words: Road trucks; Anti-biased load; Real-time monitoring; Traffic safety; stability

Introduction

In recent years, China's transport industry freight pressure is increasing, practitioners in order to pursue efficiency and ignore cargo loading norms, not only seriously endanger the life and property safety of road participants, but also increase the huge social cost, the current transport management mechanism is difficult to meet the general road freight safety requirements. The survey shows that there is a widespread phenomenon of overloading in the transportation of vehicles, and if the axle load of vehicles driving on the road exceeds 30% of the limit, the service life of the road will be shortened by 56%. At present, the safety of freight vehicles transport problems, mainly aimed at freight vehicles overload, ultra high prevention and control, often ignore the cargo load problem, the existing anti-rollover technology, only when facing dumping or other traffic accidents issued an early warning, did not consider the impact of partial load on driving, and ignore the status of goods, safety problems to correct, Can not fundamentally reduce the risk of transportation activities. Therefore, the in-depth research on the road truck anti-bias load device is not only of great significance in theory, but also has urgent practical significance in the practical transportation safety and management.

1. Research status at home and abroad

Traffic safety has always been a hot research direction in the field of traffic, and people pay special attention to the vehicle driving stability aspect of road traffic safety. At present, scholars at home and abroad pay attention to the study of how to prevent rollover when the vehicle is driving, but ignore the driving instability caused by the uneven placement of goods in the truck. The Transcell Transcell truck anti-bias system, which adopts dynamic weighing technology, can monitor the truck load in real time. When overload is detected, the system will automatically issue an audible and visual alarm. The sensor commonly used in the truck anti-bias load system abroad monitors the load of each axle of the truck in real time, and provides data support for the anti-bias load system. Luo Weifeng of Guangdong Baiyun University designed an intelligent anti-overload system for vehicles based on the Internet of Things, which realizes wireless and real-time monitoring of vehicle information and provides an efficient management method of the Internet of Things for intelligent transportation. In order to realize the intelligent anti-overloading system of truck, the domestic research team is committed to developing various algorithms. Wei He et al proposed the use of particle swarm optimization RPF neural network, and its research method provides a certain reference for the design of this project. Wang Tong analyzed the influence of biased load on vehicle weighing accuracy. This project considered the actual load bias problem, and obtained representative data by changing the weight placement center of gravity to simulate the bias in the experiment, so as to optimize the training effect and improve the accuracy. Peng Pengfeng et al. applied the photoelectric displacement sensor to analyze the data acquisition process, which provided ideas for the research design of the experiment. Based on the CAN bus protocol, Zhang Wanqing et al. designed a real-time data acquisition and monitoring system for intelligent vehicle test. PC was connected to the CAN network of the car through the CAN bus, and various parameters in the running process of the vehicle were collected in real time to realize real-time monitoring of the running state of the vehicle. Yan Qinghu et al. built a wireless wind speed monitoring system based on the Ariyun Internet of Things platform. Taking STM32 as the Internet of Things module, MQTT protocol is used to establish the connection with Alibaba Cloud server, upload the data to the cloud platform in real time and push the data to the wechat mini program, so that users can view and monitor the data remotely, which provides the idea for the connection between the data and users in this paper. The Chinese government attaches great importance to the work of anti-biased load of trucks, and has introduced a series of policy measures, such as the "Inspection Regulations for Road Freight Vehicles", which require trucks to install anti-biased load devices to improve road transport safety.

2 System composition structure

2.1 Data acquisition unit

The anti-biased load system of highway truck studied in this paper mainly consists of data acquisition unit, vehicle control unit, vehicle communication terminal and other parts. The overall structure of the system is shown in Figure 1. The data acquisition unit uses the laser displacement sensor of the same model and specifications to be installed between the truck frame and the axle through the fixed structure of the sensor, and the laser emission port is equidistant from the axle and is symmetrically distributed near the plate spring. At the same time,

the single-chip microcomputer interface is connected, and the detected distance parameters are transmitted to the single-chip microcomputer in real time through data communication. The sensor assembly structure is shown in Figure 2.

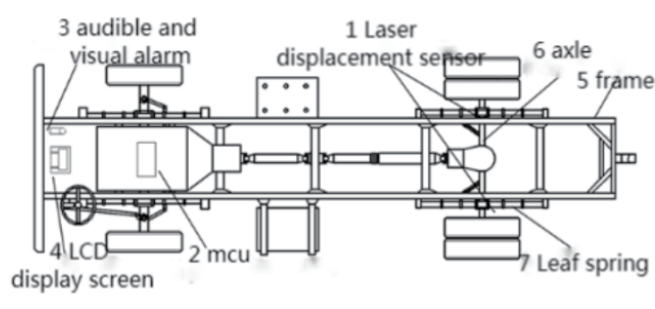

Figure 1 Top view of the structure of the anti-bias load device of highway truck

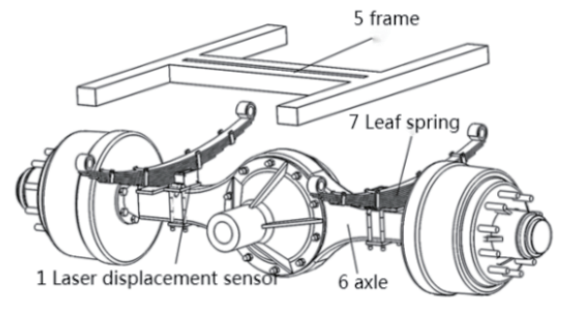

Figure 2 sensor assembly structure

2.2 Vehicle control unit

Acousto-optic alarm, LCD screen and MCU connection. 5v DC power supply is used to supply power to the single chip microcomputer. The single-chip microcomputer control system can set the off-load threshold program according to the vehicle type, reach the Angle or the height difference threshold on both sides of the body, trigger the sound and light alarm to remind the driver or staff. The LCD display screen is arranged in the cab of the truck body, and is used to display the current condition of the body and the alarm information in real time according to the Angle and the height difference between the two sides of the body sent by the single-chip microcomputer control system.

2.3 Vehicle communication terminal

Alibaba Cloud Internet of Things platform supports device and cloud access, helps the project build a powerful data channel, and realizes the interconnection between the vehicle weighing monitoring equipment and the small program on the mobile phone. The mobile end mini program mainly completes the acceptance, storage and judgment of vehicle load information. The display of vehicle location and load information, the inquiry of transport cargo history, and the supervision of overload by relevant departments are realized.

3 Working process

3.1 Collection of distance information

The laser displacement sensor is installed between the truck frame and the axle, taking the two-axis light truck as an example, the four laser displacement sensors are symmetrically distributed, and the laser emission port is in the same horizontal plane, which can monitor the distance change between the frame and the axle in real time. The laser displacement sensor is connected to the simulation input pin of the microcontroller control system (AIN0 or AIN1), and the detected distance data is sent to the microcontroller in real time, and the tilting state of the vehicle is monitored in real time. Through the microcontroller algorithm, when the tilting Angle of the truck body exceeds 10° or the center of gravity of the goods in the car changes greatly, the early warning device is started.

3.2 On-board terminal control

Connect the vehicle's ECU and dynamic control system to the MCU control system, using the CAN bus communication protocol or other appropriate communication protocol. Connect the CAN bus communication lines (CANH and CANL) to the corresponding pins of the CAN transceiver, connect the SPI interfaces of the CAN transceiver (SCK, MISO, MOSI) to the SPI pins of the single-chip control system, connect the CS pins of the CAN transceiver to the GPIO pins of the single-chip control system, Chip selection for SPI communication, connect the INT pin of the CAN transceiver to the GPIO pin of the single chip microcomputer control system in order to detect CAN messages. The single-chip microcomputer control system constantly reads the data of the tilt sensor and triggers the system response according to the tilt state of the vehicle. If the tilt Angle reaches a dangerous threshold, an audible alarm CAN be issued or the vehicle's ECU and dynamic control system can be notified via the CAN bus to perform deceleration or other control operations.

3.3 Application of function modules

Acousto-visual alarm is installed in the cab, the acousto-visual alarm is matched with the GPIO pin of the single-chip microcomputer control system. When receiving the start signal of the early warning device, the light flashes with intermittent alarm sound to remind the driver to check the tilting state of the vehicle in time, and whether the cargo stacking position is reasonable. LCD display is installed in the cab, the LCD display data line (D0-D7) and control pin (RS, RW, EN) are connected to the GPIO pin of the single-chip microcomputer control system, in order to realize the user interface single-chip microcomputer to accept the displacement sensor distance information, according to the algorithm program, Calculate the deviation distance between the two sides of the body and the front and back of the carriage, the position of the center of gravity of the goods and other information and display it on the display screen for the driver's reference. The object of this study is a truck anti-biased load device. The laser displacement sensor is installed between the axle and the frame, and is symmetrically distributed near the inside of the leaf spring, which can monitor the distance between the axle and the frame in real time. The single chip microcomputer accepts the sensor distance information, when the truck body tilt Angle exceeds 10° or the center of gravity of the goods in the carriage changes greatly, start the audible and visual alarm device, the driver can correct the truck loading state

in time according to the display information, to avoid accidents and losses of goods.

4 Epilogue

This paper studies the design and application of the anti-biased load system of highway truck, and adopts indirect measurement method for quality control. This paper focuses on the practical challenge of solving the problem of offset load in the transportation industry. Trucking plays an important role in the modern economic system, however, issues of safety and efficiency during transportation are central issues that need to be addressed. In particular, the problem of off-loading of goods not only threatens the life and property safety of road participants, but also leads to huge social costs that need to be supported by in-depth research and innovative solutions. This study highlights the urgency and importance of load condition monitoring by introducing an innovative anti-offset load device. Based on advanced sensing technology and computing power, the device realizes real-time monitoring and feedback of the loading state of the truck, as well as timely safety alerts. The application prospect of this device will undoubtedly improve the safety and efficiency of truck transportation, reduce the risk of traffic accidents, and reduce the social and economic burden. This study is only the beginning of the exploration, and future research work needs to further optimize the design of the device, taking into account the applicability of different vehicle types and road conditions, to ensure its sustainability and wide application. In addition, the formulation of relevant policies and regulations will also play a key role in facilitating the promotion and regulation of this technology.

References:

- [1] Weifeng Luo, Jiaying Wang, Guorun Chen, Jiasheng Zheng. Design of intelligent anti-overload System for Vehicle based on Internet of Things [J]. Information and Computer, 2019, (04):123-124+128.
- [2] Wei He, Xin Chen. Research on Dynamic weighing of Vehicle based on Improved RBF Neural Network [J]. Sichuan Ordnance Engineering Journal, 2021(009):042.
- [3] Tong Wang. Application Research of Vehicle Intelligent Dynamic Weighing Technology [J]. Transportation Manager World, 2021(015):112-114.
- [4] Pengfeng Peng, Xinquan Xu, Xiaomin Zhao. Truck On-Board Weighing Method Based on Improved BP Neural Network [J]. Machinery Design & Manufacture, 2022(07):97-101+107.
- [5] Qinghu Yan, Jiayuan Gong, Xuetao Wang. Design of wireless wind speed Monitoring System based on Alibaba Cloud Internet of Things Platform [J]. Journal of Hubei University of Automotive Technology, 2022, 36(03):46-50

About corresponding author: He Yongming (1979-), male, Associate Professor.

This paper is the research result of the fund project “National College Students Innovation and Entrepreneurship Training Project”, fund number: 202310225634.